

# Industrial air cooler VRB/VRZ

## Cooling/Freezing

StSt/Al - NH<sub>3</sub>

GEA Heat Exchangers



Goedhart



## Goedhart VRB/VRZ

The range Goedhart VRB/VRZ single discharge ceiling mounted industrial air coolers consists of 510 types with capacities between 3,9 and 131,3 kW. The Goedhart VRB/VRZ air coolers are suitable for cooling and freezing applications and with a wide variety of accessories and options available. The coil block is standard build from aluminium end plates, stainless steel 304 tubes and aluminium fins. The fans are arranged for blow-through air configuration for the Goedhart VRB and draw-through for the Goedhart VRZ (please state which is required when ordering).. The modular design incorporates 5 different sizes of fan, with model options of up to 4 fans per cooler

### Type-description

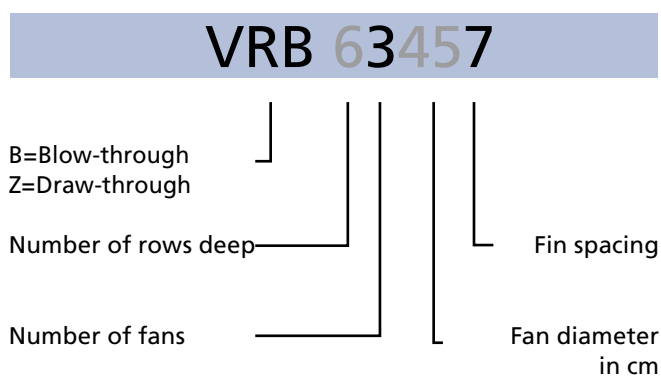

### Coil block

- Tube pitch : 50x50 mm straight
- Fin spacings : 4, 7, 8, 10 and 12 mm
- Material : 15mm o.d stainless steel 304 tubes
- : aluminium HT-fins
- Optimized cooling circuits
- Standard refrigerant connections are positioned on the left hand side of the unit when looking with the direction of the airflow.
- A good thermal contact is achieved by hydraulic expansion of the tubes into the fin collars, that are also utilised as spacers to provide a constant distance between the fins.
- All coolers are pressure tested to 30 bar (lower by cooling mediums) and are supplied with a light over pressure charge of dry nitrogen.
- Standard the air coolers are suitable for NH<sub>3</sub>-pumpcirculation (ratio 2/4).

### Casing

- Construction for ceiling mounting
- The flush mounting protects against and prevents accumulation of dust and dirt.
- Casing material of galvanized sheet steel
- Finishing is standard white epoxy spray (RAL 9003)
- Bend/header protection by end covers, easy removed for maintenance
- Hinged drip tray.
- Defrost by hot gas spiral or electric defrost elements will be fixed to the bottom side of the coil.

# General range features

## Capacity

The listed nominal cooling capacities are based on NH<sub>3</sub>, DT1 and DTM and a RH of 85%.

### Influence of Coating on Capacity

The use of coated fins, or of a fully coated coil will result in a capacity decrease of approximately 3%

### Capacity optimisation

Since Goedhart tries to limit stock products, we are capable of optimising the circuitry of our evaporators. In order to do this, the following information is needed :

- Design capacity
- Air volume
- Refrigerant
- Air on temperature
- Evaporating temperature
- Liquid temperature before expansion valve.

## Sound data

The mean sound pressure (LpA @ 3m ± 2 dB (A)) each air cooler is a calculated indication value according to the EN13487 standard parallel pipe. Goedhart uses the fan manufacturer's sound power level (LwA) at the inlet side of the fan. Changes to or by the fan or the product, affect the sound, in these cases, consult the manufacturer for the new indication value. In critical sound requirements, we advise you to consult an expert.

## Defrostsystem:

For room temperatures where ice build-up can be expected and where the coilblock can not be defrosted by the room air, electric or hotgas defrost is necessary. With low temperatures we also advise fan periphery heating.

### Electrical defrost:

The Goedhart VRB and VRZ can be provided with electric defrost. A distinction can be made here between heavy defrost loads for low temperatures and light defrost load for higher temperatures (room temperature approximately 0 °C).

The stainless steel heater elements are fitted in the coilblock in tubes, which forms a high conductive medium between the heaters and the fins. The driptray heaters are fitted to the underside of the aluminium inner tray with aluminium profiles. The heater elements which are rated for 220/240 V are connected for supply 380/415 V with neutral. The coilblock

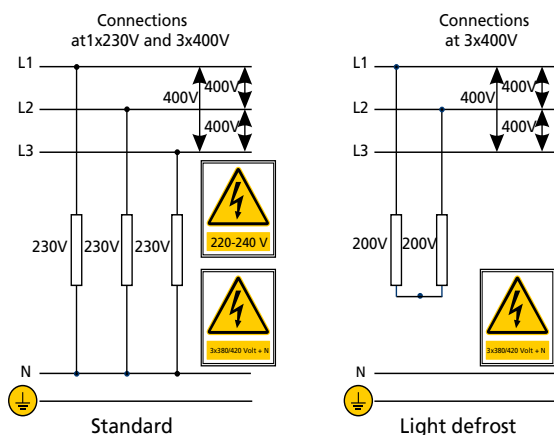

elements are removable from the end opposite to the refrigerant connections, whilst the tray heater elements can be removed once the outer tray has been taken off.

### Hotgas defrost:

The coilblock can be made suitable for hotgas. At an extra price the driptray can be provided with a hotgas/cooling medium spiral. The stainless steel tubes of the hotgas spiral are enclosed in special aluminium profiles that are rigidly secured to the underside of the aluminium inner tray, thus providing a good bond for maximum heat transfer. Just as with electric defrost a distinction is made with hotgas defrost between light defrost load (room temperature about 0°C) and heavy defrost load.

## Accessories:

Standard accessories for the Goedhart VRB/VRZ air coolers are:

- Electric, hotgas and/or water defrost system.
- Fan periphery heating.
- Insulation within the driptray.
- Insulated hygienic polyester driptray.
- Goedhart VRZ supplied with bellmouth connection per fan for a longer air throw
- Goedhart VRB supplied with air diffusor for a longer air throw
- Goedhart VRB supplied with air diffusor with air operated damper to increase defrost efficiency (air volume reduced to approx. 90% and capacity reduced to approx. 95%)

The accessories are included in the price list.

## Optional extras:

Various optional extras for the VRB/VRZ are available, price and delivery upon request:

- Insulation discs
- Feet for floor mounting
- Coating of the coilblock
- Fan hood
- 60 Hz motors
- EC-fans
- Single phase motors
- Over heat protection on the motors
- Glycol/water/etc. cooling mediums, NH<sub>3</sub> dx, R22 dx/pump-system.
- Stainless steel casing
- Coupling between hotgas spiral and coilblock
- Other fin spacings
- Stainless steel 316 tubes

## Mounting and Maintenance

Goedhart VRB/VRZ is delivered on a wooden frame. When on the frame, Goedhart VRB/VRZ can be handled by forklift truck, which makes positioning and installation simple. Refer to our maintenance and installation manual..

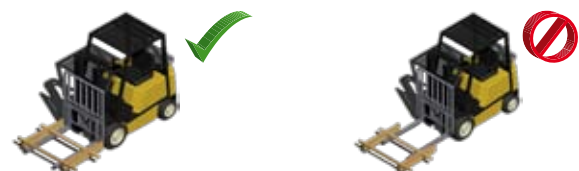

# Fans

The manufacturer of the fans is Süd Electric (we reserve the right to alter the manufacturer). The fans have glass fibre reinforced polypropylene impellers. The motors are available for 400V-50Hz-3 phase or 230V-50Hz-1 phase electrical supply. 2-Speed regulation can be achieved at 400/690V-50Hz-3 phase by using a D-Y reconnection (fig. 1). 3 Phase motors are suitable for a frequency controller (A sinus filter is needed, fig. 2). 1 Phase motors are suitable for phase control and transformer. The motors are standard executed with a thermo contact. The fans are suitable for operation in air temperature applications between -40 °C and +45 °C. When the air temperature is lower than -40 °C, special fans are needed. These special fans have a longer delivery time. The technical data in the table below are the same as on the motor name plates and is valid for an air temperature of +40 °C.

For air temperatures lower than +40 °C, the current amperage can be calculated by using the diagram multiplication factor, suitable thermal overloads can then be selected.

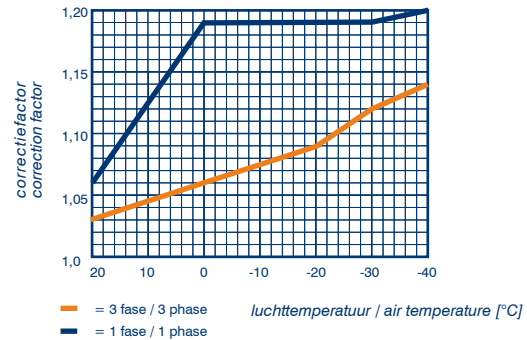

## Three phase - 50 Hz

Fan type	Tension	Δ				Y			Protection class*	Fan heating
		Speed	Input	FLC	Sound power indication each fan LwA (+/-2dB(A))	Speed	Input	FLC		
		min <sup>-1</sup>	Watt	A	dB(A)	min <sup>-1</sup>	Watt	A		

### 4 pole motor (n=1500 rpm nom.)

400-32°	3x400/690	1350	250	0.60	74	1050	150	0.30	IP44	460
450-32°	3x400/690	1350	400	0.85	78	1050	300	0.50	IP44	580
500-40°	3x400/690	1380	880	1.90	85	1050	660	1.15	IP44	580
560-36°	3x400/690	1300	1250	2.30	85	1000	750	1.30	IP66	700
630-32°	3x400/690	1300	1250	2.30	86	1000	750	1.30	IP66	820
630-28°**	3x230/400				88	1400	1400	2.50	IP66	820

### 6 pole motor (n=1000 rpm nom.)

400-28°	3x400/690	900	105	0.33	63	750	65	0.13	IP44	460
450-32°	3x400/690	900	180	0.40	69	750	120	0.20	IP44	580
500-40°	3x400/690	900	500	1.00	81	760	350	0.65	IP44	580
560-32°	3x400/690	880	680	1.60	75	680	400	0.90	IP66	700
630-36°	3x400/690	880	680	1.60	80	680	400	0.90	IP66	820

## Single phase - 50 Hz

Ventilator type	Speed	Input	FLC	Protection class*
	min <sup>-1</sup>	Watt	A	

### 4 pole motor (n=1500 rpm nom.)

400-32°	1350	450	1.95	IP44
450-32°	1350	450	1.95	IP44
500-40°	1330	700	3.40	IP44
560-36°	1350	920	4.00	IP66
630-32°	1350	1300	7.10	IP66

### 6 pole motor (n=1000 rpm nom.)

400-28°	900	250	1.10	IP44
450-32°	900	250	1.10	IP44
500-40°	900	400	1.75	IP44
560-32°	870	700	3.40	IP66
630-36°	870	700	3.40	IP66

\*= IP44 motors also available in IP66 execution (extra price)

\*\*= Only freezing conditions

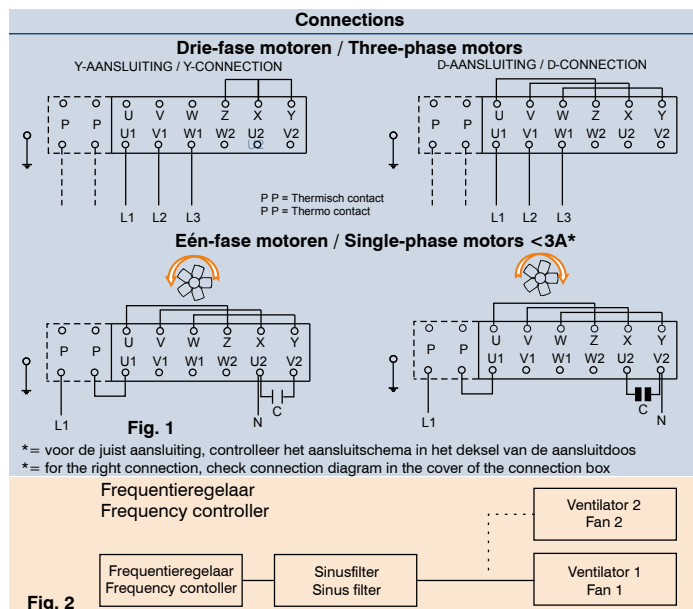

# Correction factors

## Capacities at DTM:

The capacities are based on NH<sub>3</sub> pump system and the difference between the mean air temperature and the evaporation temperature (DTM). The evaporation temperature is the saturated temperature corresponding to the pressure at the suction outlet of the cooler. The nominal capacities are based on evaporation temperatures of -5 °C and -25°C, a DTM of 7 K and light frosting. Capacities for other mediums and systems are available upon request.

Correction factors for various mean air temperatures and evaporation temperatures (DTM) are as indicated in the tables below.

The requested capacity must be multiplied by a correction factor from one of these tables.

$$Q_{\text{nominal}} = \text{factor} \times Q_{\text{requested}}$$

## Capacities at DT1:

Hereby the capacities are based on NH<sub>3</sub> pump system and DT1. DT1 is the difference between air-on temperature and the evaporation temperature of the cooler. The evaporation temperature is the saturated temperature corresponding to the pressure at the suction outlet of the cooler. The nominal capacities are based on evaporation temperatures of -8°C and DT1=8K and -25°C and DT1=7K and light frosting.

Capacities for other mediums and systems are available upon request.

Correction factors for various air-on temperatures and temperature differences (DT1) are as indicated in the table below. The requested capacity must be multiplied by a correction factor from the table, so that a cooler with the resulting nominal capacity can be chosen from the selection tables.

$$Q_{\text{nominal}} = \text{factor} \times Q_{\text{requested}}$$

### NH<sub>3</sub> light frost = 0.2 mm RV = 85%

DTM	Evaporation temperature (°C)														
	K	0	-2,5	-5	-7,5	-10	-12,5	-15	-20	-22,5	-25	-27,5	-30	-32,5	-35
5	1.44	1.49	1.54	1.59	1.62	1.65	1.69	1.51	1.52	1.54	1.56	1.58	1.60	1.61	
6	1.14	1.18	1.23	1.26	1.29	1.31	1.32	1.18	1.20	1.22	1.23	1.25	1.26	1.28	
7	0.93	0.97	1.00	1.03	1.05	1.07	1.09	0.97	0.99	1.00	1.01	1.03	1.04	1.05	
8	0.79	0.82	0.85	0.87	0.88	0.90	0.92	0.82	0.83	0.85	0.86	0.87	0.88	0.89	
9	0.68	0.71	0.73	0.75	0.76	0.77	0.79	0.71	0.72	0.73	0.74	0.75	0.76	0.77	
10	0.61	0.61	0.64	0.65	0.67	0.68	0.69	0.62	0.63	0.64	0.65	0.66	0.66	0.67	
11	0.53	0.55	0.57	0.58	0.59	0.60	0.61	0.55	0.56	0.57	0.58	0.58	0.59	0.60	
12	0.47	0.49	0.51	0.52	0.53	0.54	0.55	0.50	0.50	0.51	0.52	0.52	0.53	0.54	

DT1	Evaporation temperature (°C)														
	K	0	-2,5	-5	-7,5	-10	-12,5	-15	-20	-22,5	-25	-27,5	-30	-32,5	-35
5	1.63	1.69	1.75	1.80	1.85	1.90	1.95	1.48	1.51	1.54	1.57	1.60	1.63	1.65	
6	1.29	1.34	1.39	1.43	1.47	1.50	1.54	1.17	1.20	1.22	1.24	1.26	1.29	1.31	
7	1.06	1.11	1.14	1.17	1.21	1.24	1.26	0.97	0.99	1.00	1.02	1.04	1.06	1.07	
8	0.90	0.94	0.97	1.00	1.02	1.04	1.06	0.82	0.83	0.85	0.86	0.88	0.89	0.91	
9	0.78	0.80	0.84	0.86	0.88	0.90	0.92	0.70	0.72	0.73	0.75	0.76	0.77	0.78	
10	0.68	0.70	0.74	0.76	0.78	0.79	0.80	0.62	0.63	0.64	0.65	0.66	0.67	0.69	
11	0.61	0.63	0.66	0.68	0.69	0.70	0.71	0.55	0.56	0.57	0.58	0.59	0.60	0.60	
12	0.54	0.56	0.59	0.60	0.62	0.63	0.64	0.49	0.50	0.51	0.52	0.53	0.54	0.53	

 = calculated without frost layer

 = calculated without frost layer

### NH<sub>3</sub> normal frost = 0.5 mm RV= 85%

DTM	Evaporation temperature (°C)														
	K	0	-2,5	-5	-7,5	-10	-12,5	-15	-20	-22,5	-25	-27,5	-30	-32,5	-35
5		1.67	1.72	1.77	1.80	1.83	1.86	1.65	1.67	1.69	1.71	1.74	1.76	1.77	
6		1.32	1.37	1.39	1.42	1.45	1.48	1.31	1.32	1.34	1.36	1.38	1.39	1.41	
7		1.10	1.13	1.16	1.17	1.19	1.21	1.08	1.09	1.11	1.12	1.13	1.15	1.16	
8		0.92	0.95	0.97	0.98	1.00	1.02	0.91	0.92	0.94	0.95	0.96	0.97	0.98	
9			0.82	0.83	0.85	0.87	0.88	0.79	0.80	0.81	0.82	0.83	0.84	0.85	
10			0.72	0.74	0.75	0.76	0.77	0.69	0.70	0.71	0.72	0.73	0.74	0.74	
11			0.64	0.65	0.66	0.67	0.69	0.62	0.63	0.63	0.64	0.65	0.66	0.66	
12			0.57	0.58	0.60	0.61	0.62	0.55	0.56	0.57	0.58	0.58	0.59	0.59	

DT1	Evaporation temperature (°C)														
	K	0	-2,5	-5	-7,5	-10	-12,5	-15	-20	-22,5	-25	-27,5	-30	-32,5	-35
5		1.86	1.92	1.98	2.03	2.08	2.13	1.68	1.71	1.73	1.74	1.76	1.79	1.80	
6		1.48	1.52	1.57	1.61	1.65	1.68	1.33	1.34	1.35	1.37	1.38	1.39	1.40	
7		1.22	1.26	1.29	1.33	1.36	1.39	1.08	1.09	1.10	1.11	1.12	1.13	1.14	
8		1.04	1.07	1.09	1.12	1.14	1.16	0.91	0.92	0.93	0.95	0.96	0.97	0.98	
9			0.92	0.95	0.97	0.99	1.00	0.79	0.80	0.81	0.81	0.82	0.83	0.84	
10			0.81	0.83	0.85	0.86	0.88	0.69	0.70	0.71	0.71	0.72	0.74	0.74	
11			0.72	0.74	0.76	0.77	0.78	0.61	0.62	0.63	0.64	0.64	0.65	0.66	
12			0.65	0.67	0.68	0.69	0.70	0.55	0.56	0.57	0.58	0.59	0.60	0.61	

## Attention!

### Moisture carry over from the coil block:

When you select VRB with a Ø500 mm fan in an application with a high relative humidity and/or defrost with room air, Goedhart advises the use of a fan with a low pitch angle or the draw-through execution VRZ. Thus, you will avoid the risk of moisture carry over from the coil block. The fan with a low pitch angle give a reducing of the capacity of approx. 5% and a reduction of the air volume of approx. 10%.

### ATTENTION !!!

When making your selection, pay attention to the ratio between the airvolume and capacity. A low volume to capacity ratio results in a wide temperature drop across the coil which cause to dry out (especially on coils with a high number of rows deep).



# VRB/VRZ Electrical defrost

Type	Light defrost			Heavy defrost		
	Coil	Drip tray	Total	Coil	Drip tray	Total
	kW	kW	kW	kW	kW	kW
3/4.1.40.f	1.64	1.06	2.70	2.46	1.40	3.86
3/4.1.45.f	1.64	1.18	2.82	2.46	1.58	4.04
3/4.1.50.f	2.12	1.30	3.42	3.18	1.76	4.94
3/4.1.56.f	3.18	1.42	4.60	4.24	1.94	6.18
3/4.1.63.f	5.90	1.54	7.44	7.08	2.12	9.20
3/4.2.40.f	2.60	1.66	4.26	3.90	2.30	6.20
3/4.2.45.f	3.08	1.77	4.85	4.62	2.48	7.10
3/4.2.50.f	3.54	2.13	5.67	5.31	3.02	8.33
3/4.2.56.f	6.06	2.37	8.43	8.08	3.18	11.26
3/4.2.63.f	10.65	2.53	13.18	12.78	3.54	16.32
3/4.3.45.f	4.26	2.53	6.79	6.39	3.54	9.93
3/4.3.50.f	5.20	2.12	7.32	7.80	4.24	12.04
3/4.3.56.f	8.52	2.30	10.82	11.36	4.60	15.96
3/4.3.63.f	15.40	2.48	16.64	18.48	4.96	23.44
3/4.4.50.f	6.64	2.64	9.28	9.96	5.28	15.24
3/4.4.56.f	10.62	3.02	13.64	14.16	6.04	20.20
3/4.4.63.f	20.20	3.18	21.79	24.24	6.36	30.60
5/6.1.40.f	1.64	1.06	2.70	3.28	1.40	4.68
5/6.1.45.f	2.46	1.18	3.64	3.28	1.58	4.86
5/6.1.50.f	3.18	1.30	4.48	4.24	1.76	6.00
5/6.1.56.f	4.24	1.42	5.66	6.36	1.94	8.30
5/6.1.63.f	5.90	1.54	7.44	7.08	2.12	9.20
5/6.2.40.f	2.60	1.66	4.26	5.20	2.30	7.50
5/6.2.45.f	4.62	1.77	6.39	6.16	2.48	8.64
5/6.2.50.f	5.31	2.13	7.44	7.08	3.02	10.10
5/6.2.56.f	8.08	2.37	10.45	12.12	3.18	15.30
5/6.2.63.f	10.65	2.53	13.18	12.78	3.54	16.32
5/6.3.45.f	6.39	2.53	8.92	8.52	3.54	12.06
5/6.3.50.f	7.80	2.12	9.92	10.40	4.24	14.64
5/6.3.56.f	11.36	2.30	13.66	17.04	4.60	21.64
5/6.3.63.f	15.40	2.48	16.64	18.48	4.96	23.44
5/6.4.50.f	9.96	2.64	12.60	13.28	5.28	18.56
5/6.4.56.f	14.16	3.02	17.18	21.24	6.04	27.28
5/6.4.63.f	20.20	3.18	21.79	24.24	6.36	30.60
8.1.40.f	2.46	1.06	3.52	4.92	1.40	6.32
8.1.45.f	3.28	1.18	4.46	4.92	1.58	6.50
8.1.50.f	4.24	1.42	5.66	6.36	1.76	8.12
8.1.56.f	6.36	1.94	8.30	8.48	1.94	10.42
8.1.63.f	8.26	2.12	10.38	10.62	2.12	12.74
8.2.40.f	3.90	1.66	5.56	7.80	2.30	10.10
8.2.45.f	6.16	1.77	7.93	9.24	2.48	11.72
8.2.50.f	7.08	2.13	9.21	10.62	3.02	13.64
8.2.56.f	12.12	3.36	15.48	16.16	3.18	19.34
8.2.63.f	14.91	3.54	18.45	19.17	3.54	22.71
8.3.45.f	8.52	2.53	11.05	12.78	3.54	16.32
8.3.50.f	10.40	2.12	12.52	15.60	4.24	19.84
8.3.56.f	17.04	4.60	21.64	22.72	4.60	27.32
8.3.63.f	21.56	4.96	26.52	27.72	4.96	32.68
8.4.50.f	13.28	2.64	15.92	19.92	5.28	25.20
8.4.56.f	21.24	6.04	27.28	28.32	6.04	34.36
8.4.63.f	28.28	6.36	34.64	36.36	6.36	42.72
1.1.40.f	2.46	1.18	3.64	4.92	1.40	6.32
1.1.45.f	3.28	1.30	4.58	4.92	1.58	6.50
1.1.50.f	4.24	1.76	6.00	6.36	1.76	8.12
1.1.56.f	6.36	1.94	8.30	8.48	1.94	10.42
1.1.63.f	8.26	2.12	10.38	10.62	2.12	12.74
1.2.40.f	3.90	1.77	5.67	7.80	2.30	10.10
1.2.45.f	6.16	1.89	8.05	9.24	2.48	11.72
1.2.50.f	7.08	3.02	10.1	10.62	3.02	13.64
1.2.56.f	12.12	3.36	15.48	16.16	3.18	19.34
1.2.63.f	14.91	3.54	18.45	19.17	3.54	22.71
1.3.45.f	8.52	2.53	11.05	12.78	3.54	16.32
1.3.50.f	10.40	4.24	14.64	15.60	4.24	19.84
1.3.56.f	17.04	4.60	21.64	22.72	4.60	27.32
1.3.63.f	21.56	4.96	26.52	27.72	4.96	32.68
1.4.50.f	13.28	5.28	18.56	19.92	5.28	25.20
1.4.56.f	21.24	6.04	27.28	28.32	6.04	34.36
1.4.63.f	28.28	6.36	34.64	36.36	6.36	42.72

f = fin spacing

# VRB Drawing

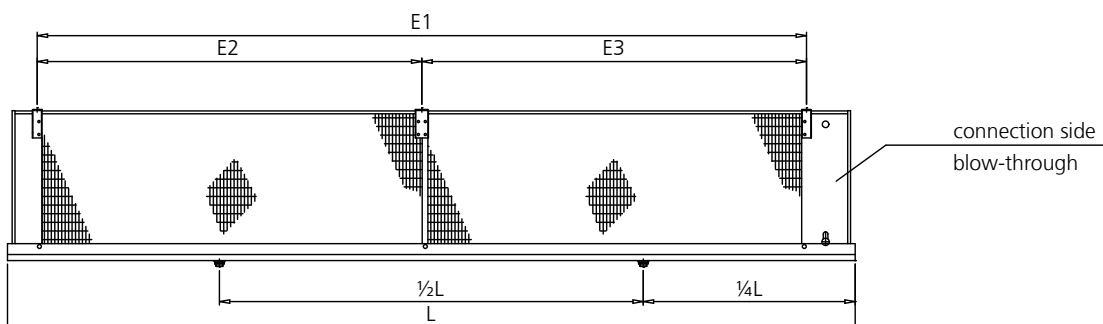
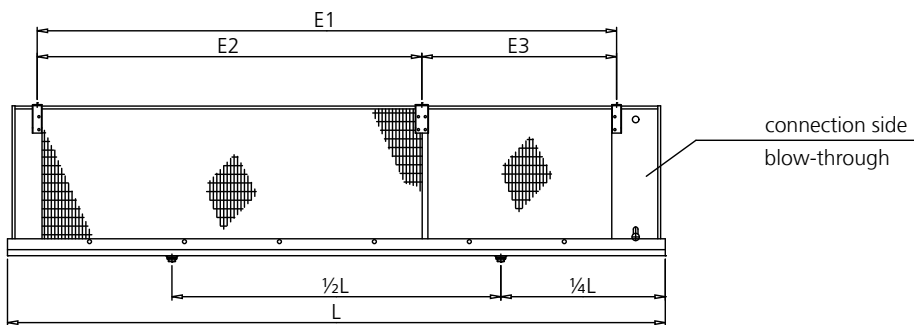
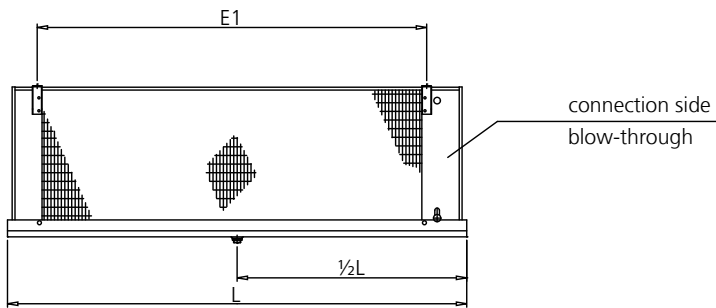
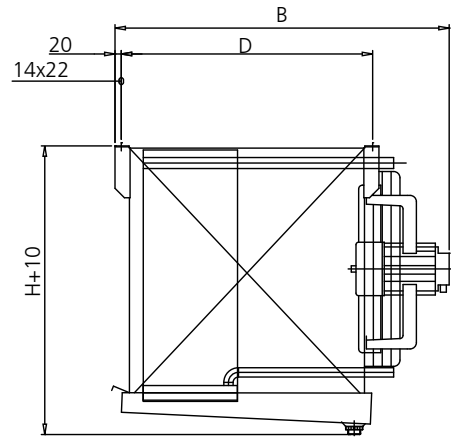
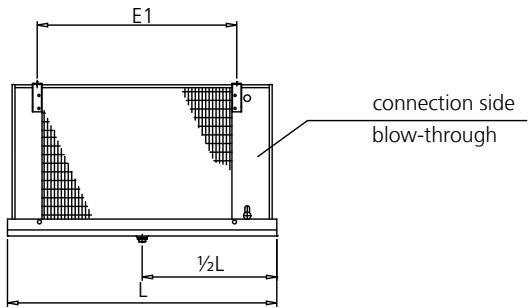



# VRZ Drawing

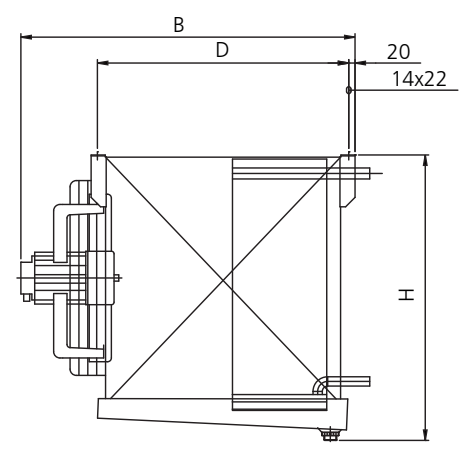
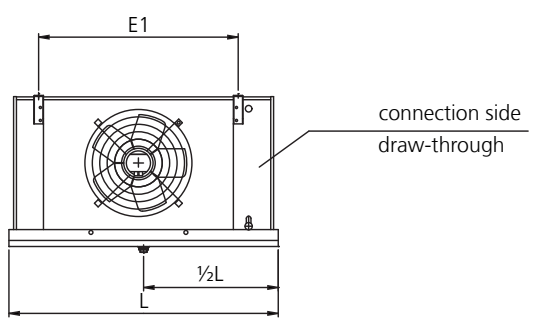

Air configuration : Draw through

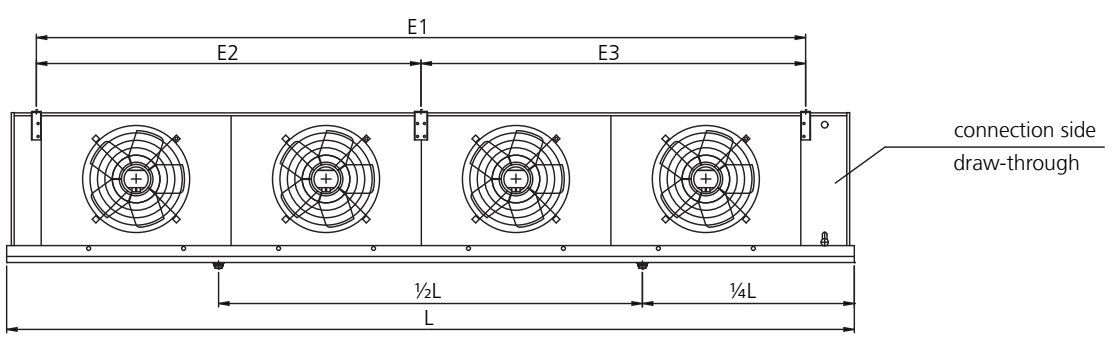
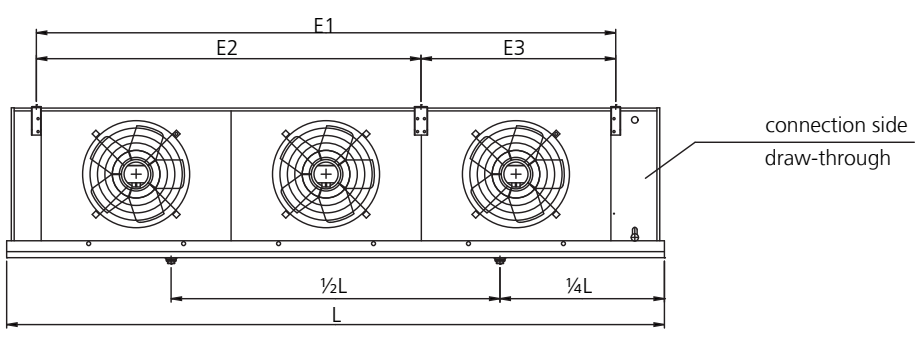
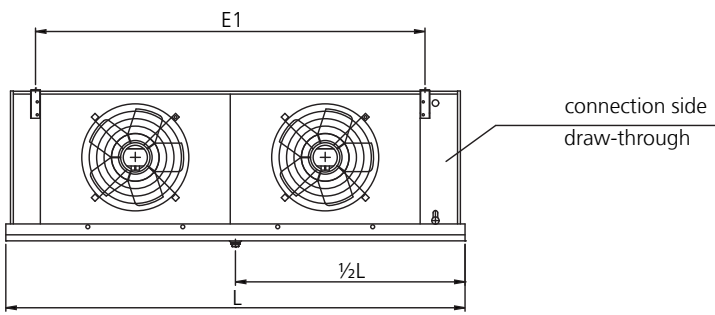

# Goedhart standard product information

## Goedhart standard aircooler overview



VCI



DVS/DRS/DZS



ZGB/ZGZ



PAC



FC38



ZFB/ZFZ



# Goedhart air cooler for every application

For Contractors and Original Equipment Manufacturers (OEM) related to the industrial refrigeration industry, GEA Goedhart B.V. offers an unlimited range of air coolers and air cooled condensers in several configurations.

Depending on the application, the optimum configuration will be selected in close cooperation with our customers.

## Configurations

The following material combinations are available in various tube pitches and various fin spacing:

Tube material	Tube configuration	Fin material
Copper (Cu)	38x33, 50x50, 60x60	Aluminium (Al)
Stainless steel (Stst)	38x33, 50x50, 60x60	Aluminium (Al)
Stainless steel (Stst)	50x50	Stainless steel (Stst)
Aluminium (Al)	60x60	Aluminium (Al)
Hot dipped galvanized steel (FeZn)	60x60, 75x75	Hot dipped galvanized steel (FeZn)

## Options on aluminium fins

- Goldlack coated fins
- Seawater resistant aluminium fins (AlMg)

## Applications

Cooling	Freezing
Cold stores / Distribution centres	Cold stores / Distribution centres
Food processing rooms	Tunnel / spiral freezers
Fruit storage	Slaughter houses
Banana ripening storage	Automotive testing rooms
Greenhouse conditioning	Ski domes

## Pressure Equipment Directive (P.E.D.)

All aircoolers produced by Goedhart comply with the Pressure Equipment Directive 97/23/EC. PED certificates can be downloaded from [www.goedhart.nl](http://www.goedhart.nl).





GEA Heat Exchangers

## GEA Goedhart B.V.

Nijverheidsweg 6, 4695 RC Sint Maartensdijk  
the Netherlands  
Phone +31 (0)166 665 665, Fax+31 (0)166 663 698  
[www.goedhart.nl](http://www.goedhart.nl)  
[info.goedhart.nl@geagroup.com](mailto:info.goedhart.nl@geagroup.com)

GEA Heat Exchangers

## GEA Goedhart s.r.o.

Kostomlátecká 180, 288 26 Nymburk  
Czech Republic  
Phone +420 (0)325 819 951, Fax+420 (0)325 519 952  
[www.goedhart.cz](http://www.goedhart.cz)  
[goedhart.cz@geagroup.com](mailto:goedhart.cz@geagroup.com)

06.01.2.005.dok - 2010-01 / Subject to modification

All offers, contracts, deliveries and other legal relations from GEA Goedhart B.V. are subject to the latest version of our general sales and delivery conditions as filed at the Chamber of Commerce in Middelburg - The Netherlands

Applicability of the general conditions put forward by any buyer is rejected explicitly by GEA Goedhart B.V.